



# FHG-L

Models 20, 30, 40, and 50

## Technical Datasheet



### Froling FHG-L

The FHG-L is a patented, wood-fired gasification boiler available in two sizes with outputs from 70,000-170,700 Btu/hr.



### Benefits at a Glance:

- Add on to your existing fossil-fuel-fired or electric heating system
- Can be used with hot water baseboard, radiant floor, or hot air systems.
- Overall efficiencies of over 80%.
- Clean burn with virtually no smoke or creosote.
- Large easily accessible firebox.
- Smoke-free loading.
- Easy to clean manual; turbulators for heat exchanger tubes.
- Covered by a 20-year limited warranty.

---

Boiler Information  
Boiler Overview

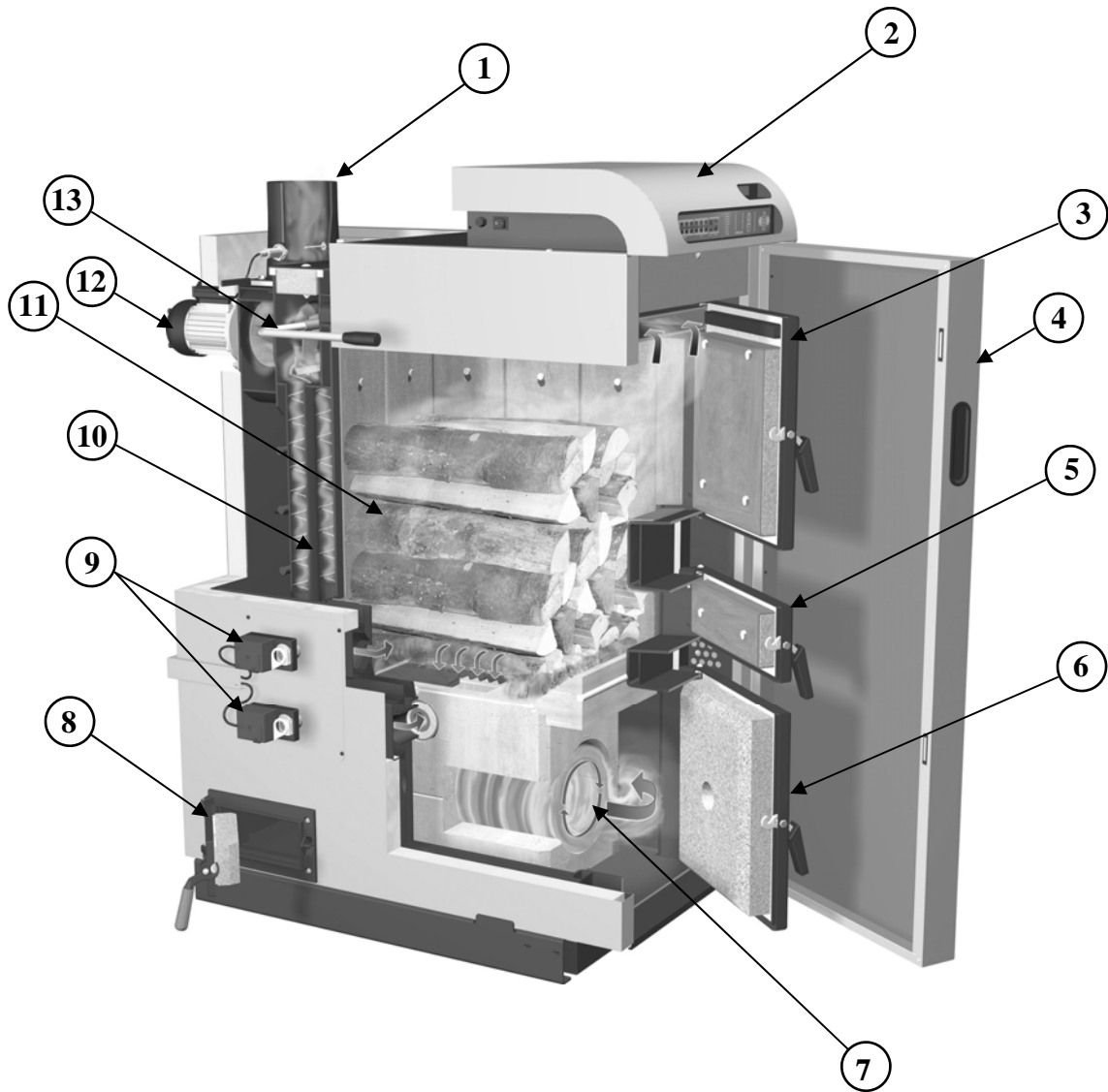

- |   |  |
|---|--|
| 1. Exhaust Stack                              | 8. Side cleaning port door                             |
| 2. Lambdatronic S 3200 control                | 9. Server-controlled primary and secondary air dampers |
| 3. Fuel loading door                          | 10. Heat Exchangers                                    |
| 4. Insulating door for reduced heat radiation | 11. Firebox  |
| 5. Pre-heating chamber                        | 12. Draft Fan  |
| 6. Combustion chamber door                    | 13. Lever for heat exchanger cleaning system           |
| 7. Combustion chamber                         |  |

## Specification Data

Component	Units	FHG 20	FHG 30	FHG 40	FHG 50
Depth-Boiler-Total	inches	45.25	45.5	49.5	49.5
Width-Boiler-Total	inches	22.75	22.75	22.75	22.75
Height-Boiler-Total	inches	61.75	62	65.75	65.75
Flue Collar Diameter	inches	6	6	6	6
Rated Heat Output	Btu/Hr	70,000	102,500	136,560	170,700
Heating Efficiency Range	Btu/Hr	35,000-70,000	51,250-102,000	68,280-136,560	85,350-170,700
Electrical Connection	V/Hz	240/60	240/60	240/60	240/60
Electrical Consumption	W	180	180	180	180
Output Temperature Range	°F	158-194	158-194	158-194	159-194
Boiler Weight	Pounds	1150	1150	1345	1345
Loading Door	inches	13 X 14½	13 X 14½	13 X 14½	13 X 14½
Firebox Volume	Cu Ft	5	5	7.4	7.4
Wood Length	inches	21	21	21	21
Water Contents	Gallons	32	32	50	50
Upstream Resistance	Psi	.042	.094	.157	.245
Minimum Return Feed Temperature	°F	131	131	131	131
Maximum Operating Temperature	°F	203	203	203	203
Maximum Operating Pressure	Psi	43.5	43.5	43.5	43.5
Permitted Fuel		Firewood	Firewood/Coarse Waste-Wood	Firewood/Coarse Waste-Wood	Firewood/Coarse Waste-Wood
Boiler Test Pressure	Psi	65	65	65	65
Flue Gas Temperature Rated Load/Partial Load	°F	303/203	329/212	311/214	253/223
Minimum Draft Required Rated Load/Partial Load	Inch WC	-0.060/-0.028	-0.060/-0.040	-0.072/-0.040	-0.072/-0.040

## Specification Data

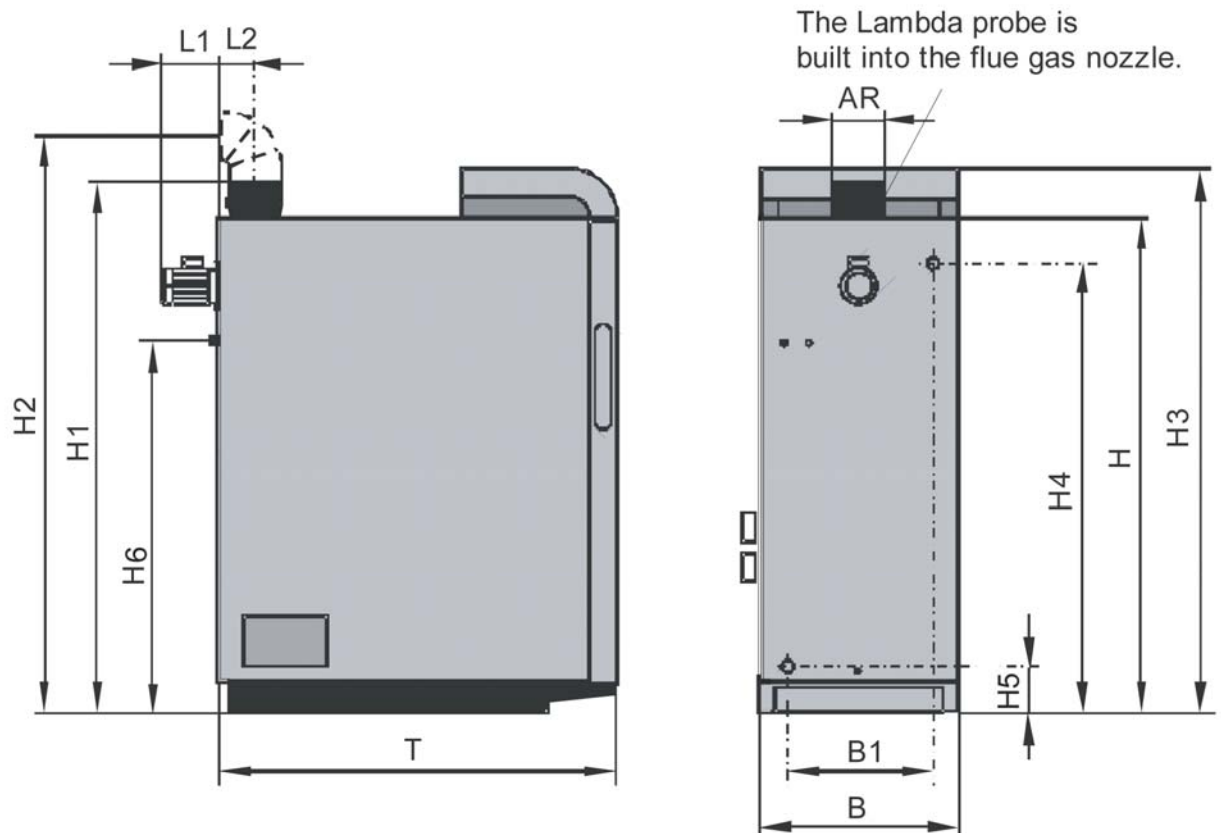

Description	Units	FHG20/30	FHG40/50
H- Total Height of Boiler	inches	56	60
H1-Height of Flue Gas Pipe Connection	inches	60 $\frac{1}{4}$	64
H2-Height of Flue Gas Pipe Connection Including an Elbow	inches	69	72 $\frac{3}{4}$
H3-Total Height of the Boiler Including the Controller	inches	61 $\frac{3}{4}$	65 $\frac{3}{4}$
H4-Height of Supply Feed Connection	inches	50 $\frac{1}{4}$	54
H5-Height of Return Feed Connection	inches	5	5
B-Total Width of Boiler	inches	22 $\frac{3}{4}$	26 $\frac{3}{4}$
B1-Width Between Supply and Return Feed Connections	inches	14	18
T-Boiler Total Depth	inches	45 $\frac{1}{2}$	50 $\frac{1}{4}$
L1-Length of Induced Draft Fan	inches	7	7
L2-Distance between center of Flue Pipe and Back of Boiler	inches	4 $\frac{1}{4}$	4 $\frac{1}{4}$

Boiler Clearances

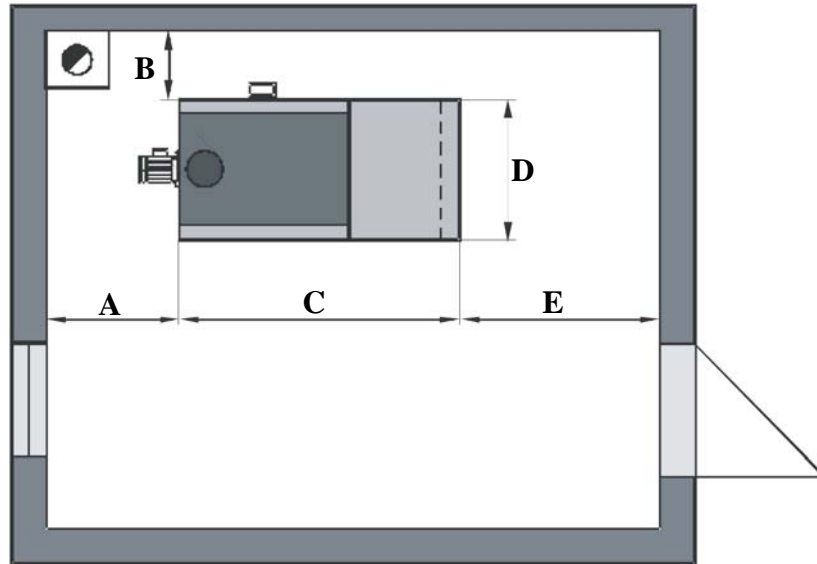

Clearances to Combustibles			
Measurement	Units	FHG 20/30	FHG 40/50
A-Backwall to Appliance	inches	21	21
B-Sidewall to Appliance	inches	12-20	12-20
C-Boiler Depth	inches	45½	50¼
D-Boiler Width	inches	22½	27
E-Distance in Front of Boiler	inches	32	32
Combustibles to Flue Pipe	inches	18	18

---

## System Design Considerations

### Sizing

It is critical to size the boiler properly. A proper, up to date heat load calculation is advised. An accurate history of building fuel usage over several years can help to calculate the proper size boiler. Be wary of using simple techniques based only on square footage. The heat load of a home can vary widely depending on age and type of heating system and location of the home. Boiler sizing is the responsibility of the installer. Tarm Biomass bears no responsibility for boiler sizing, but can provide sizing input.

### Chimney

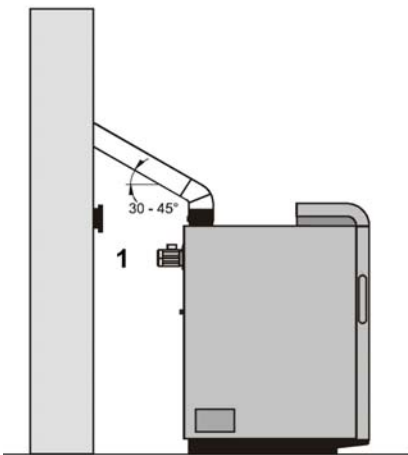

The chimney is the most critical factors in the successful operation of any solid fuel heater, including the FHG-L boiler. A good chimney will provide a continuous and dependable draft to pull the exhaust gasses out of the building. The boiler must be connected to a tile-lined masonry chimney or to a Factory-Built Type UL 103 HT (ULC S629 in Canada) approved chimney. The chimney must be in good condition. If the boiler is connected to a dirty or inadequate chimney, it can present a serious fire hazard. All chimney connections must conform to NFPA standard #211. No other appliance should be con-

nected to this flue unless allowed by the local code authority. Consult your local inspector for chimney requirements and install the boiler in accordance with all applicable codes.

The installation of a barometric damper (1) is recommended. The barometric damper should be mounted under the mouth of the flue gas pipe, since an under-pressure condition can always be found there.

### Outside Combustion Air

Provision for outside combustion air may be necessary to ensure that fuel-burning appliances do not discharge products of combustion into the house. Guidelines to determine the need for additional combustion air may not be adequate for every situation. If in doubt, it is advisable to provide additional air.

The FHG-L boiler is not suitable for direct connection to outside air. Outside air should be ducted to no closer than 12" from the boiler.

The boiler must not be installed in an area or room where there are flammable liquids or combustibles. Examples include, refrigerants, paint, thinner, bleach, etc.

### Boiler Location

The boiler is not suitable for outdoor installation. It must be located in a weather-tight, protected space. The boiler must be placed on a level, non-combustible floor, such as a concrete slab on earth. If the boiler is placed near inhabited rooms, so that the flue gas can easily penetrate into these rooms, a carbon monoxide alarm must be installed that can give a warning regarding possible escapes of carbon monoxide into the inhabited rooms.

### Electrical

For the FHG-L boiler a 240 VAC, 60 hertz, 4 wire power supply is required. This electrical connection should be from a dedicated 15 amp, circuit breaker. A master service switch for the boiler, mounted on the wall in the proximity of the boiler, is recommended. Locally enforced electrical codes must be followed.

### Water Quality

If water quality is poor, water treatment should be considered. Boiler system pH should be 8.0-8.6.

An anti-freeze can be utilized in areas where freezing could occur. Automotive or silicate-based anti-freeze cannot be used. Use only anti-freeze approved for heating systems. Using anti-freeze can cause a loss in heating efficiency and some heating components within the system could be negatively impacted.

### System Plumbing

For the heating system piping, it is possible to use either copper or iron piping materials. The supply and return pipe should be insulated to avoid heat loss.

In systems where plastic tubing is used, it must have an oxygen diffuser barrier. If non-oxygen barrier tubing is used, the boiler must be separated from the tubing by a heat exchanger.

A thermostatic mixing valve, set to open at 140 °F (60 °C), is required to temper return water to prevent cold return water from reaching the boiler. This valve helps prevent boiler corrosion.

### Boiler Accessories

- **Termovar Mixing Valve**
- **Termovar Loading Unit**
- **Aquastats**
- **Thermal Storage Systems**